

Coupling Module

Ethernet Interface on the Station bus

1KGF 100 881, Edition 12/04

87TS50-E/R1214

Application

The 87TS50 module is a coupling module for connecting MMI systems, such as the **P**lant **M**anagement **S**ystem 'PMS', to a PROCONTROL system.

Communication between the MMI system and the PROCONTROL system takes place, on the computer side, with the help of the CPS software package (**C**ommon **P**ROCONTROL **D**ata **S**erver), and on the PROCONTROL side, through the 87TS50 module.

The CPS controls the 87TS50 and conditions the signals for the MMI system.

The 87TS50 is connected via a thin-wire Ethernet interface acc. to IEEE 802.3.

A total of four 87TS50 modules can be connected to one CPS interface. The module's scope of action extends over the entire PROCONTROL system where it is being used.

It is possible to plug a maximum of four 87TS50 modules linked to one and the same CPS interface into different PROCONTROL systems, i.e. into systems using different system addresses (cf. 'Connection diagram').

The module is also suitable for redundant-station arrangements. It may be operated in two modes:

- Redundant mode
- Partial-redundant mode

Module application in redundant stations as described below:

- 'Redundant' mode

When used in the passive REDUNDANCY, the sending of send-location telegrams and destination telegrams to the PROCONTROL bus and of the listen-in data to the CPS is being suppressed.

- 'Partial-redundant' mode

When used in the passive REDUNDANCY, the sending of send-location telegrams and destination telegrams to the PROCONTROL bus is being suppressed.

The CPS can set or reset diagnosis message 'Bus coupling fault'. Therefore, a redundancy changeover may be effected due to a disturbed CPS computer.

Features

This module can be plugged into any station of the PROCONTROL bus system. It uses a standard interface with the PROCONTROL station bus.

The telegrams received over the bus are checked by the module for error-free transmission based on their parity bits. Through its Ethernet interface, the module can receive or put out instructions and data, according to the TCP/IP protocol, to or from the CPS.

From the CPS, the 87TS50 module can exchange the following data with the entire PROCONTROL system:

- Listening-in on up to 16383 telegrams.

The listen-in address list is generated independently by the coupling module after having received a connect instruction from the CPS.

The coupling module is able to independently learn listen-in addresses (e.g. of new modules plugged in).

As soon as they have been received from the PROCONTROL bus, the data telegrams are provided with the time stamp used on the module. The resolution valid for the time stamp is one millisecond.

All listened-in telegrams are subjected to receive monitoring.

The quantity of messages of the listen-in telegrams can be adjusted by setting global thresholds and time-outs.

- Sending up to 800 send-location telegrams.

The address for sending is determined by the slot used for the module and by the specifications made by the CPS.

- Sending destination telegrams for writing into PROCONTROL module registers, for instance for command output.

The module requires redundant +24 V operating voltages USA and USB.

The operating voltages refer to reference conductor Z.

On the module front, indicators signal the following conditions:

- | | |
|--------|--------------------|
| - ST | Disturbance |
| - SG | Module disturbance |
| - HLT | Processor halt |
| - RUN | Active |
| - MODE | Operating status |

For commissioning and service purposes, the module is equipped with a user interface (monitor) which can be used to call up all important information regarding telegram data and module-specific configurations. The ambient temperature of the module can be read from register 202.

Marginal application conditions

The module uses 2 slots on the PROCONTROL subrack. When used in cabinets without forced ventilation, one slot to the left and to the right of the module is to be kept free in order to make for sufficient cooling. If two 87TS50 modules are installed next to each other, only one division between the modules needs to be left unoccupied. It is also permissible to mount a 87TS50 module on slot 1 of the subrack. In case more than 400 send-location telegrams are sent by the 87TS50 module, additional slots need to be reserved (for module addresses), cf. chapter on 'Output of send-location telegrams'.

The 87TS50 module is intended to be used in new station-bus cabinets type 89MS01/Rx200 or 89MS02/Rx100. In case the module is to be used in PROCONTROL station-bus cabinets type ZS1, special adjustments need to be made.

- The SRA line (contact d18) has to be connected to a ZD contact (contacts b2, b14, d26) per wire-wrap on that subrack where the module is being used.
- In the ZS1 cabinet, the module only uses the USA supply. A redundant supply as in the case of the 89MS01/02 cabinets is not possible.
- The -24 V supply (contact z32) must not be connected on the subrack where the module is being used. Consequently, the module has only one contact available for reference point ZD.

Note:

- Stations, where the 87TS50 is being used, are privileged stations with a maximum of 2048 response telegrams handled in cyclic mode. For this purpose, the following settings need to be programmed on the communication controller (88VA01/VA02):
 - 2048 telegrams
 - Privileged station
- It may be possible that older modules, supplied before 1988 and installed in the same station, are not recognized by the 87TS50. For retrofitting old systems, it is therefore advisable to install the 87TS50 either as a single module or in conjunction with new modules (using SAB14/SAB16).
- If, during the learning of the address list, stations are not being recognized, the cause lies with the module using the highest module address in those stations. This module sends its data only with an event bit. Following causes are possible:

Module 87TS01 in the mode for sending send-location telegrams.

 - Remedy: Changing the location of the 87TS01 module

Modules are using an outdated bus program.

 - Remedy: Plugging-in the new module one address higher (e.g. 81EB03 or 83SR04).
- The 87TS50 module stores information in its RAM. In order to make sure that this RAM has been deleted completely, the module may be plugged in again only after waiting for approx. 10 sec.

Design of the module

The module essentially consists of:

- Station-bus interface
- Processing section
- Ethernet and serial interface

Station-bus interface

The station-bus interface adapts the module signals to the bus. The station-bus interface partly performs the processing of the listen-in telegrams.

After a connect instruction from the CPS, the station-bus interface determines the data telegrams present on the PROCONTROL bus, and generates the listen-in address list. After the listen-in address list has been generated, these telegrams can be listened-in on and subjected to receive monitoring.

Furthermore, (during learning mode) a checking function continuously checks whether new telegrams need to be included in the listen-in address list.

The listen-in mode, i.e. receiving, monitoring (receive monitoring) and learning certain telegram addresses from the overall amount of telegrams of the PROCONTROL system and their processing, can handle a maximum of 16383 telegrams.

With the connect instruction, the CPS can specify the data types to be listened-in on.

A telegram-image memory and a FIFO memory are used for decoupling the processing function from the station-bus interface of the 87TS50.

With the connect instruction, the CPS provides the information required for defining the range on the listen-in address list available for the station addresses to be processed, the occupancy level of the listen-in address list and the data types to be processed, and for activating the independent learning mode.

Immediately after having been received from the PROCONTROL bus, the telegrams are given the time stamp used on the module. For this purpose, the station bus interface keeps and updates the date and the time.

The resolution valid for the time stamp is one millisecond.

Processing section

This section of the 87TS50 performs the following functions:

- Control and monitoring of the station-bus interface
- Data-type-specific processing of the telegrams on the station-bus interface
- Generating and managing the data for sending send-location telegrams to the station-bus interface
- Generating the data for sending destination telegrams to the station-bus interface
- Receiving and processing jobs from the CPS and sending telegrams to the CPS
- Synchronizing with CPS
- Generating system messages to the CPS
- Recognizing redundancy changeovers
- Service and commissioning interface (monitor)

Telegram acquisition and processing

The received and time-stamped data telegrams are transferred to the CPS if they have changed as compared to their previous state and if the criteria for data-type-specific processing are fulfilled.

All listened-in telegrams are subjected to receive monitoring. The response of the receive monitoring function causes a mark being set in the change message to the CPS.

The listen-in address list is generated automatically based on the connect instruction and its specific information (range of station addresses to be processed, occupancy level of the listen-in address list, and data types to be processed) and on the telegrams actually present on the PROCONTROL bus. This information is also used for the learning mode (the occupancy level of the listen-in address list excepted).

The module can listen-in on telegrams of data types 0-24, 26 (32-bit counter, 32-bit binary data with time stamp and 16-bit binary data with time stamp), 28 and 29 (32-bit counter and time telegrams from the system clock).

The 87TS50 receives every telegram transferred over the PROCONTROL bus. The telegrams for listening-in are selected based on the listen-in address list. Then, the activities of data-change recognition and time-stamping are carried out. For telegrams of data type 26 (16, 32-bit binary data with time stamp), the time stamp received with the telegrams is used. If a change is detected, the changed telegram is transferred to the CPS for processing.

For setting the quantity of messages for the listen-in mode, several data-type-specific functions are available on the 87TS50:

- Change recognition for analog values based on the integration method (time value-change threshold).

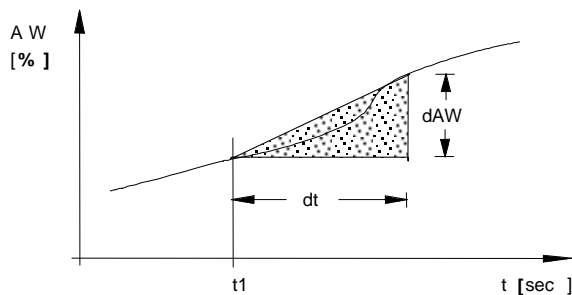

t_1 = time of last value updating

An analog value is updated again if the product obtained from the time passed (dt) and the analog-value change (dAW) exceeds a defined minimum value, i.e. the surface value.

The surface value can be adjusted within 0.1 ... 6.35 % sec and is based on the 0-100 % representation in the PROCONTROL telegram.

Default setting of the surface value corresponds to a value of 0.5 % sec. This parameter can be specified by the CPS to apply to all analog value telegrams, and can be changed during operation.

- Handling analog-value telegrams with frequently changing disturbance bits.

Analog values, whose disturbance bits change more frequently than n times in m seconds, will be indicated to the CPS only if the analog value has changed as well. Changes of an analog value exceeding the surface value are always forwarded, even in the case of an activated suppression due to a disturbance bit change.

- Handling binary-value telegrams in the case of a frequently changing binary signal.

Binary-value telegrams, whose binary signals change more frequently than n times in m seconds, are not transferred to the CPS. Binary-signal changes of the telegram that are not suppressed continue to cause messages to the CPS.

- Handling counter-telegrams in the case of frequently changing counter values.

Counter telegrams, whose values change more frequently than n times in m seconds, are indicated to the CPS only once per monitoring time m if a new counter value is received.

If the suppression function responds, a status message for the telegram concerned is generated and sent to the CPS.

Parameters n and m are specified from the CPS. They apply to all analog, binary, counter and listen-in telegrams.

n = number of changes, adjustable within 1 ... 127

m = monitoring time, adjustable within 80 msec ... 10 sec

Default setting is: 5 changes within 5 sec.

Valid ranges of PROCONTROL addresses and data types in listen-in telegrams:

Station address: 1-249

Module address: 0-63

Register address: 0-199,

246 TK, TV, TR modules

Data types: 0-24, 28

26 32-bit counter,
32-bit binary data
with time stamp and
16-bit binary data
with time stamp,

29 32-bit counter and system clock

During 'Redundant' mode, the sending of listen-in data to the CPS is being suppressed in the passive REDUNDANCY. When there is a redundancy changeover from passive to active, in a background cycle all listen-in data are transmitted once to the CPS in parallel with the change messages.

Output of send-location telegrams

The 87TS50 can send up to 800 send-location telegrams under 4 consecutive slot addresses. Using its own slot address, the module sends 200 send-location telegrams. The CPS can determine the number of send-location telegrams to be sent. Per command, the CPS can start or stop the output of send-location telegrams and can change the telegram contents.

First transmission as well as subsequent value changes in the telegrams are transmitted over the PROCONTROL bus per event. Then, transmission will be cyclic.

The PROCONTROL address for the output of send-location telegrams is generated from:

- System address:
corresponding to the system address of the bus system.
- Station address:
corresponding to the station address where the 87TS50 is plugged into.
- Module address:
corresponding to the slot address of the module (also slot address +1...3 possible for putting out send-location telegrams in the range 200-800; these addresses must not be used by adjacent modules).
- Register address:
0 ... 199; defined by the CPS.

The PROCONTROL data type and the data of the send-location telegrams are specified by the CPS.

In the passive REDUNDANCY, the sending of send-location telegrams is suppressed if the 87TS50 is operating in the redundant mode.

Output of destination telegrams

The 87TS50 can send destination telegrams per event in order to write into PROCONTROL module registers. In that case, the CPS specifies the PROCONTROL address (corresponding to the address of the register on the destination module) as well as the data. The 87TS50 automatically checks the data written by reading them back and puts out an acknowledgement signal to the CPS.

In the passive REDUNDANCY, the sending of destination telegrams is suppressed if the 87TS50 is operating in the redundant mode.

Clock synchronizing

On the 87TS50 all listened-in telegrams are, immediately upon reception from the PROCONTROL system, provided with a time stamp. The time resolution used by the 87TS50 is 1 msec.

The internal clock of the 87TS50 is continuously synchronized with the PROCONTROL system clock (87TS01/Rx313) by cyclically receiving time telegrams. When several 87TS50 modules are used, they are synchronized at a time difference of 0.1 msec. In the case of failure of the PROCONTROL system clock, the clock on the 87TS50 will continue to operate without being synchronized.

In addition, a time-synchronizing signal is sent cyclically to the CPS at intervals as configured by the CPS.

User interface (monitor)

For supporting the commissioning and service activities, the 87TS50 is provided with a menu-based user interface

suitable to read and display internal module states and data. Display is possible via the serial interface (X1 on the module front) on a terminal or a computer with terminal emulation or via the Ethernet interface of the CPS computer using a monitor program.

This monitor is started automatically after the 87TS50 is plugged in, i.e. after the module has reached at least operating state 6 'Waiting for TCP/IP connect'. The terminal can be plugged in or removed during operation. For the operation of the monitor, please refer to the 'Operating Instructions User Monitor' for the 87TS50-E/R1213 module (Publication No. D KWL 6310 96 E).

The following data/functions can be called up:

- Connect status
- Internal 87TS50 module time and its status
- Bus-cycle time
- Range and contents of the listen-in address list
- Distribution of listen-in telegrams according to data types
- Calculation values for telegram processing:
time and value-change threshold
- Number of telegrams in the FIFO
- Number of telegrams from the bus system per second
- Number of messages to the CPS per second
- Listen-in telegram status
(receive monitoring / time stamp)
- Contents of the listen-in telegram
- List of 16 telegrams with the highest change rate:
 - from the bus system
 - to the CPS
- Contents of the 87TS50 system registers
- Module description
- Scope and contents of the output of send-location telegrams
- Contents of the last destination telegrams put out
- Current Ethernet and Internet address
- Current hardware stamp

Ethernet interface

The 87TS50 modules are connected via a thin-wire Ethernet interface (50 W coaxial cable) to the CPS. A total of 4 modules can be cascaded. Both ends of the connection must be terminated by means of a 50 W terminator. The line up to the last connection must not be longer than 180 m. The distance between 2 participants must be at least 0.5 m.

The modules are given a unique and fixed Ethernet address in the factory. The Internet address required for connecting it to the CPS is set at the monitor specifically for the project.

Serial interface according to RS232

On the module front, a 9-pole connector X1 is located which is used for connecting the module to the user interface (monitor). Either a terminal (VT100 and higher) or another computer with a terminal emulation can be used.

Diagnosis and monitoring

The diagnosis functions monitor the telegram transfer to the PROCONTROL system as well as the internal processing.

Monitoring of the internal processing includes the following:

- Monitoring all processing functions in cooperation with a hardware watchdog.
- Monitoring the Ethernet connection CPS/87TS50 based on a 'live' signal (optional activation from the CPS).
- Filing the internal user data (listen-in address list, processing parameters) on parity-controlled memories.
- CRC protection for the module programs.
- Temperature monitoring on the 87TS50 module.
- Generating system messages to the CPS.

The temperature monitoring puts out a warning for values <5 °C and >55 °C, and a fault signal for values <0 °C and >60 °C.

The monitoring of the internal processing makes sure that the 87TS50 is restarted automatically in the event of a disturbance. After restart, the 87TS50 is ready again to take up the connection with the CPS via the Ethernet interface.

Monitoring of telegram transfer includes the following activities:

- All listen-in telegrams are checked for fault-free condition (CRC check code). The send telegrams are given a CRC check code.
- All listen-in telegrams are subjected to receive monitoring.
- Disturbances of the telegram transfer are indicated on the CPS.
- Station-bus failure, remote-bus failure.

Furthermore, disturbances are indicated in a diagnosis telegram to the PROCONTROL system.

Initialization

The initialization of the module takes place in two phases. Both phases are run through automatically.

The initialization of the modules towards the bus system takes place when the power is connected, i.e. when the module is plugged into the module slot. During this initialization phase, all LEDs of the module are illuminated at first. The individual segments of the operating-status display are activated one after the other within approx. 5 sec. During this time, the user may interrupt to enter a new Internet address.

After the operating-status display has reached value '1', the initialization phase of the processing section begins. The operating-status display now counts from 1 to 6. In state 6, the module waits for a TCP/IP connect from the CPS. The two disturbance lamps ST and SG still emit a steady light.

- After a successful TCP/IP connect, the operating-status display will enter state '7'.

- A CPS connect causes the listen-in address list to be generated and the initial-value signal to be transmitted to the CPS. The operating-status display indicates state '8'.

After all initial-value signals have been transmitted, continuous processing is active. The operating-status display shows value '9'. Disturbance lamps ST and SG will go off.

From this time on (with the learning mode being active), new telegrams can be learned.

The RUN LED indicates the processor's activity.

Starting in redundant stations

Starting the modules in redundant stations means plugging the modules into operating stations or switching on stations with the modules being installed, and then performing a TCP/IP connect from the CPS.

- Plugging the modules into operating stations (redundancy 'READY', no 'Disturbance' LEDs on).
Procedure:

- Plugging into the passive station (ST/SG on, module runs up to state 6 = waiting for TCP/IP connect)
-> redundancy disturbed, redundancy not 'READY'.
- Plugging into the active station (ST/SG on, module runs up to state 6 = waiting for TCP/IP connect)
-> redundancy disturbed, redundancy not 'READY'.

- Switching-on stations with the modules installed.
Both modules run up to state 6 = waiting for TCP/IP connect (ST/SG on).
-> both redundancies disturbed, not 'READY'.

After the following TCP/IP connect effected by the CPS (modules running in state 7 = waiting for CPS connect, ST/SG on), there are the following possibilities:

- The CPS first establishes a connection to the 87TS50 in the active station (module runs through state 8 up to state 9 = telegram processing active)
-> redundancy not disturbed, redundancy not 'READY'.
Then, the CPS establishes a connection to the 87TS50 in the passive station (module runs through state 8 up to state 9 = telegram processing active)
-> both redundancies not disturbed, redundancy 'READY'.
- The CPS first establishes a connection to the 87TS50 in the passive station (module runs through state 8 up to state 9 = telegram processing active)
-> redundancy changeover (station becomes active).
Then, the CPS establishes a connection to the 87TS50 in the now passive (previously active) station (module runs through state 8 up to state 9 = telegram processing active)
-> both redundancies not disturbed, redundancy 'READY'.

Annunciation functions

Defects of the module or of the interfaces are recognized and indicated by the diagnostic functions of the module.

Annunciations on the module

On the module front, three red and one green light-emitting diode as well as one green operating-status display are located:

- LEDs ST and SG

Red LEDs ST and SG emit a steady light:

- if a disturbance has been detected in the area of the station-bus interface,
- if a disturbance has been detected in the area of the processing section,
- if operating state 'Telegram processing active' has not been reached yet,
- if diagnosis message 'Bus coupling fault' has been set from the CPS.

Cf. Figure '87TS50-E/R1214 diagnosis messages', page 8.

- Light-emitting diode HLT

Red light-emitting diode HLT emits a steady light if the processor is at a halt.

- Light-emitting diode RUN

Green light-emitting diode RUN is illuminated when processing is active. The brightness depends on the processor workload.

- Operating-status display

For more error and status indications, the green operating-status display with indicators 0-9 and A-F is being used. Indicators 1-5 show dynamic processes. In the case of a fault, the respective indicator flashes for approx. 5 sec. The watchdog forces the processing to run through a restart after the programmed waiting time has expired.

- 0 Boot monitor active
- 1 Processing self-test
- 2 Waiting for enabling of shared memory
- 3 Shared-memory test active
- 4 Interrupt test active
- 5 Initialization of station-bus interface
- 6 Waiting for TCP/IP connect
- 7 Waiting for CPS connect
- 8 Address-list generating and telegram initial-value processing active
- 9 Telegram processing active
- A Address error; causing restart
- B Bus error; causing restart
- C Parity error; causing restart
CRC error; no restart
- D Runtime error; causing restart
- E Exception error; causing restart
- F Temperature error detected

Module operating

Diagnosis register 246

Bit	Type
15	0
14	0
13	S
12	S
11	0
10	S
9	D
8	S
7	S
6	0
5	0
4	S
3	S
2	S
1	0
0	0

CDS messages *)

Module not operating

Initialization of processing active
Telegram processing not active

Firmware invalid or missing
Hardware defect of processing section

Module not accessible from bus

Init. of bus interface active
Module address 0-58
Module transmitter ON
Station address received
No bus program
Hardware defect of bus interface

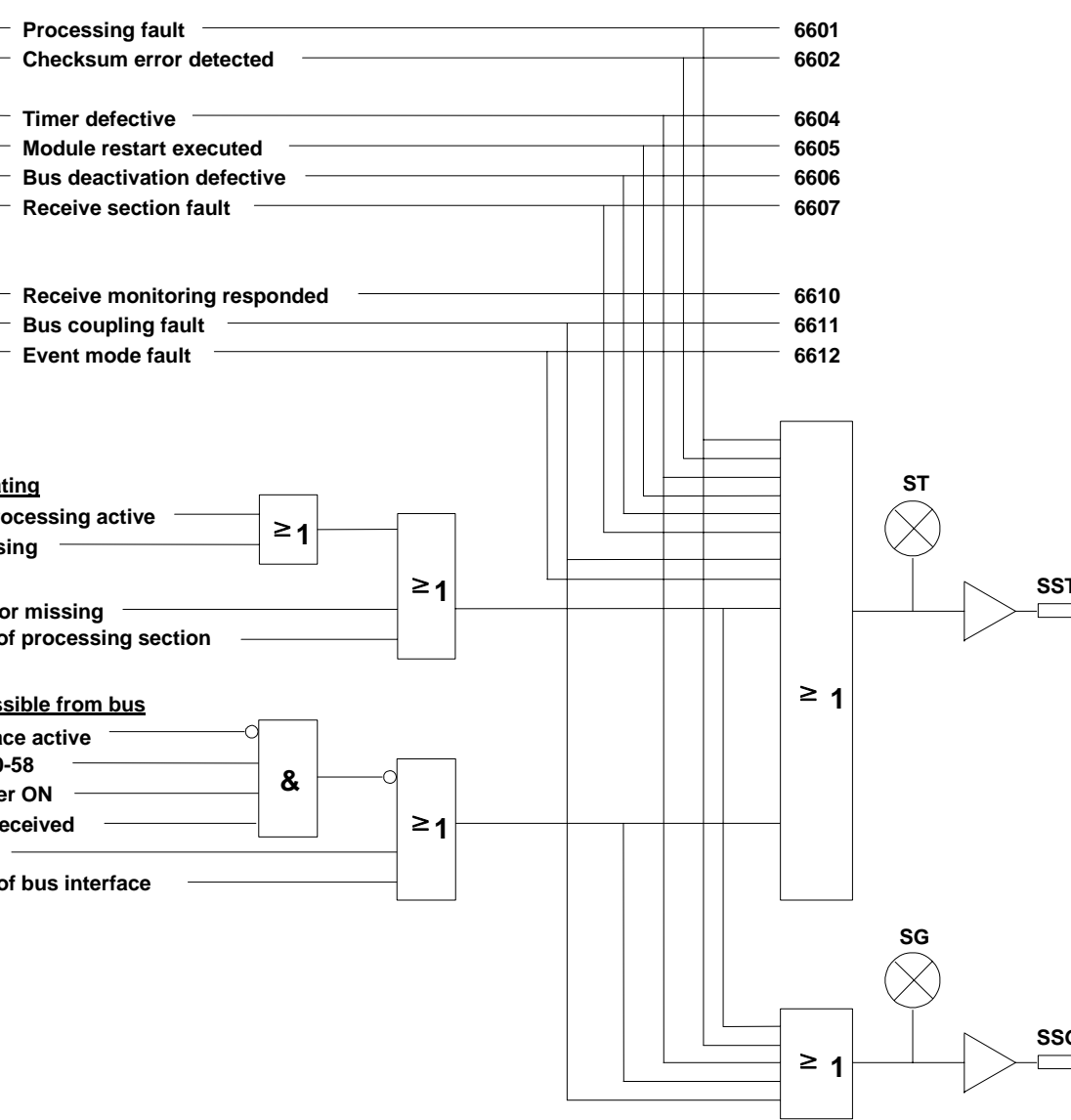

D = Dynamic annunciations are cancelled after the contents of the diagnosis register has been transmitted
S = Static annunciations disappear automatically upon deactivation
0 = Not used

87TS50-E/R1214 diagnosis messages, register 246

*) The control diagnosis system (CDS) provides a description for every message number. This description comprises:

- Information on cause and effect of the disturbance
- Recommendations for elimination.

Thus, fast disturbance elimination is ensured.

Background diagnosis registers 211 and 227

Cause for 'Processing unit fault' (register 227/bit 15)Background
diagnosis register 211

Bit	Type
15	0
14	0
13	0
12	0
11	0
10	0
9	0
8	0
7	0
6	0
5	0
4	0
3	0
2	S
1	0
0	0

Host computer fault
Ethernet reception disturbed

Station-bus failure
Remote-bus failure
Module transmitter OFF

Cause for 'Bus coupling fault' (register 246/bit 3)Background
diagnosis register 227

Bit	Type
15	S
14	S
13	0
12	0
11	0
10	S
9	S
8	S
7	V
6	V
5	0
4	0
3	0
2	V
1	V
0	V

Current signalling status

History values

V = History values are deleted only upon restart of the module
S = Static annunciations disappear automatically upon deactivation
0 = Not used

Connection diagram

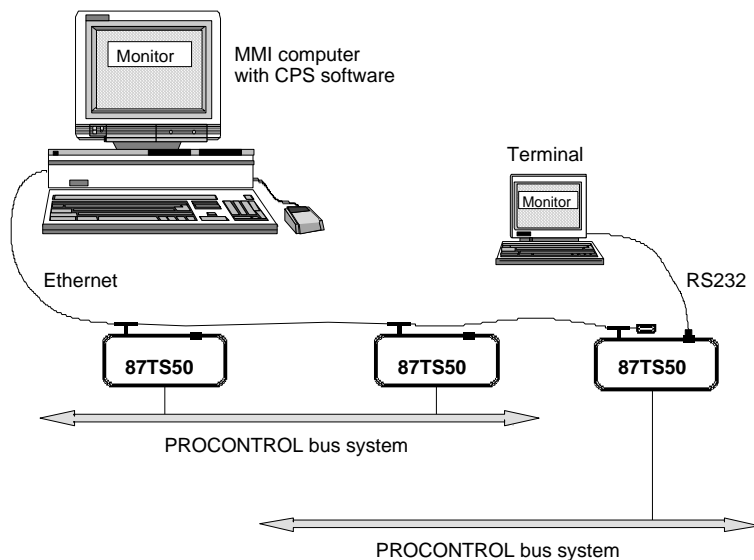

1 ... 4 87TS50 modules, optionally allocated to different PROCONTROL bus systems using different system addresses

Mechanical design

Board size: 6 units, 2 divisions, 160 mm deep

Connector:

- 1 x for station-bus connection, 48-pole edge connector, type F (connector X11)
- 1 x for V24 interface, 9-pole edge connector, type D (connector X1)
- 1 x for Ethernet interface, BNC jack (connector X2)

Weight: approx. 0.78 kg

View of connector side:

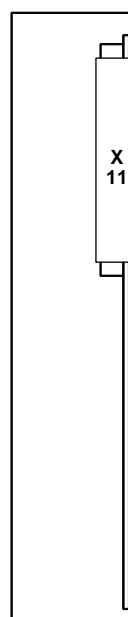

View of module front and module side

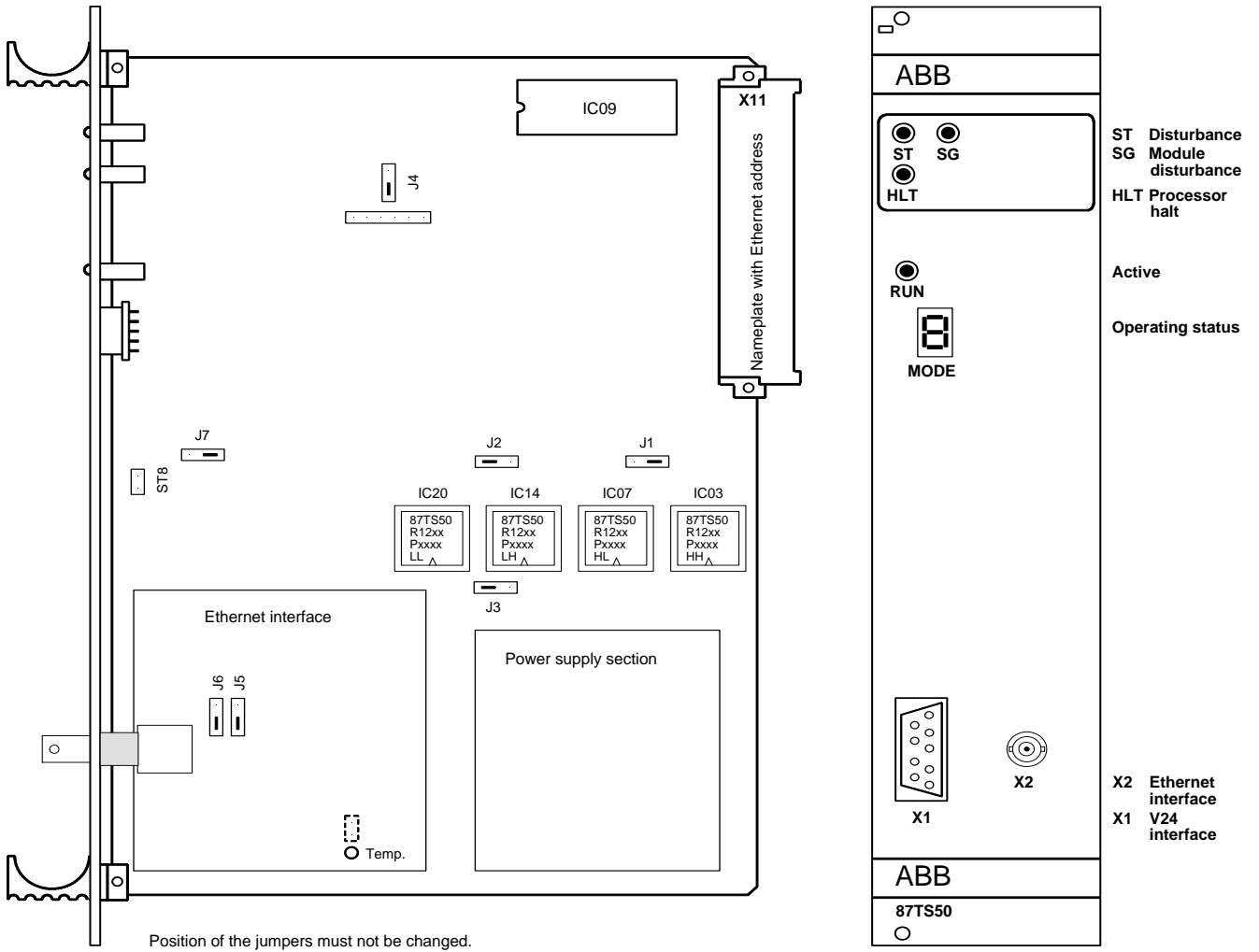

Cable connections/pin assignments

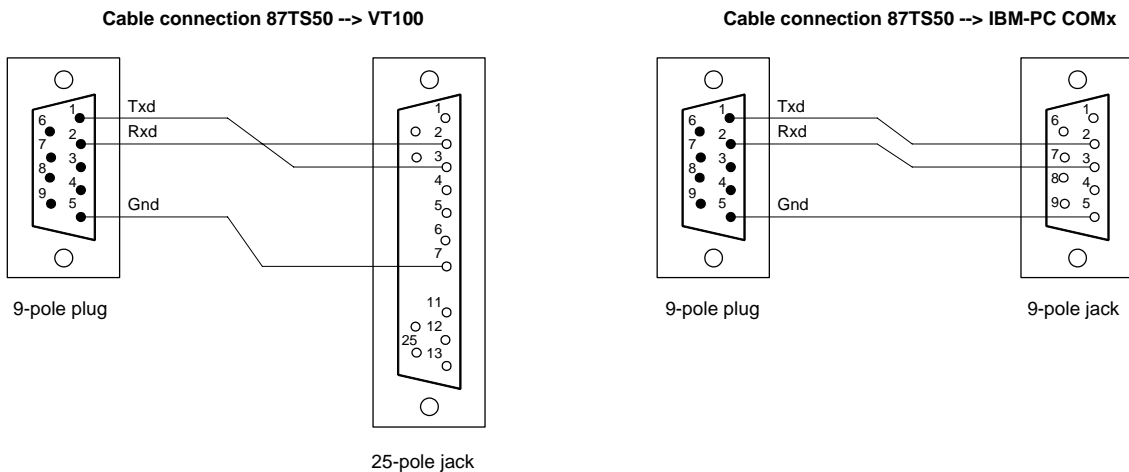

Configuration of the Ethernet interface

The modules are activated from the CPS via the Ethernet interface (connector X2).

The network address is composed of the Ethernet and the Internet address. The Ethernet address is factory-set on every 87TS50.

The Internet address has to be adjusted to the individual project and has to be available on the 87TS50 modules as well as on the CPS. In a network, all connected modules must have a different Internet address.

Setting of the Internet address is done - before the 87TS50 is commissioned - following the steps described below:

- 1 Connect a VT100 terminal or personal computer with VT100 emulation to the 87TS50.
- 2 Plug the module onto the subrack.
Output :

```
87TS50 BOOT MONITOR, REL :....., autoboot in progress
type any key to break
```

- 3 Press any key while the individual segments of the mode display are activated one after the other. This activates the monitor.
Output:

```
B  continue autoboot
I  internet address
T  special tools
```

- 4 Entry of 'I' causes deletion of the DRAM (clear DRAM) and displays the current Internet address in decimal form.
Output :

```
act.internet address (dec) : 138.222.10.00
<CR> exit, c change :
```

The address put out here is exemplary.

- 4.1 Entry of '<CR>' ends the 'Internet address' menu.
Continue with step 5.
- 4.2 Entry of 'C<CR>' allows to change the Internet address in decimal form.
Output:

```
internet address (dec) → d1.d2.d3.d4 :
```

Input :

```
138.222.70.41 <CR>
```

Output :

```
→ AM 29F010 found
flash clear.... ok.
internet address (dec) 138.222.70.41
```

- 5 The following menu appears:

```
<CR> internet address, B continue autoboot :
```

- 5.1 Entry of '<CR>' allows to change the Internet address again (as in step 4).
- 5.2 Entry of 'B<CR>' enables a direct start of the module using the current Internet address (without step 6, 7).
- 6 Remove module and then enter the configured Internet address on the Internet address label on connector X11 of the module.
- 7 Plug the module onto the subrack again. It will operate now with the new addresses.

Please consider:

- Handling of the Internet addresses is centralized.
- All Internet addresses mentioned before are exemplary!

Note:

<CR> means 'Press the ENTER or RETURN key'. The statement in brackets () is the short instruction in the "User Monitor".

Technical data

In addition to the system data, the following values apply:

Power supply

Operating voltage module	USA/USB = 24 V
Current consumption	IS = 700 mA
Power dissipation	PV = 15 W
Reference potential on the bus side	ZD = 0 V

Ambient conditions

Temperature	T = 0 ... 70 °C
Relative humidity	F = 95 % E without condensation

Interference immunity (of process inputs and outputs)

Electrostatic discharge immunity	DIN EN 61000-4-2	8 kV / 4 kV
Radiated, radio-frequency, electromagnetic field, immunity	DIN EN 61000-4-3	10V/m
Electrical fast transient/burst immunity	DIN EN 61000-4-4	0,5 kV
Surge Immunity	DIN EN 61000-4-5	2 kV / 1 kV
Conducted disturbances immunity	DIN EN 61000-4-6	10 V

Module interfaces

X1	Serial interface acc. to RS232
X2	Ethernet interface acc. to IEEE 802.3
X11	Station-bus interface

Ethernet interface acc. to IEEE 802.3

Application	Interfacing a computer
Transmission protocol	TCP/IP
Transmission rate	10 Mbits/sec
Transmission distance	Up to 180 m (without line amplifier)
Minimum distance between participants	0.5 m
Number of participants (87TS50)	Up to 4
Cable type and connectors	50 Ω coaxial precision cable for thin-wire Ethernet systems acc. to IEEE 802.3-10 BASE 2. GKWN 000 270

Serial interface according to RS232

Application	User interface (monitor)
Transmission protocol	Serial according to RS232
Transmission rate	9600 baud
Transmission mode	8 data bits, 1 stop bit, NO parity, XOFF handshake
Transmission distance	Up to 15 m (without line amplifier)
Terminal setting	Wraparound ON

Quantities

Number of listen-in telegrams	1 ... 16383
Number of send-location telegrams (cf. chapter on 'Marginal application conditions')	0 ... 800

System throughput

Throughput of listen-in telegrams for continuous operation. The system throughput is primarily determined by the calling sequence of the CPS ≤ 500 telegrams/sec

Buffer capacity for listen-in telegrams available on the 87TS50 in the case of large quantities of messages 12288 telegrams

Ordering data**Order no. for complete module**

Type: 87TS50-E/R1214

Order no.: GKWE857800R1214

Order nos. for plug-in memory modules

Memory module	Position	Order number
Bus-interface section	IC09	GKWE857856Pxxxx
Processing section, low/low	IC20	GKWE857857Pxxxx
Processing section, low/high	IC14	GKWE857858Pxxxx
Processing section, high/low	IC07	GKWE857859Pxxxx
Processing section, high/high	IC03	GKWE857860Pxxxx

Pxxxx = Position number indicating the applicable program version.

Technical data subject to change without notice!

**ABB Utilities GmbH**

Postfach 10 03 51

D-68128 Mannheim

Kallstadter Straße 1

D-68309 Mannheim

Telefon: +49 (0) 621 381-2712

Telefax: +49 (0) 621 381-5958

E-Mail: powertech@de.abb.com

Internet: www.abb.de/utilities

NOTE:

We reserve the right to make technical changes or modify the contents of this manual without prior notice. With regard to purchase orders, the agreed particulars shall prevail.

ABB does not accept any responsibility whatsoever for potential errors or possible lack of information in this document.

We reserve all rights in this document and in the subject matter and illustrations contained therein. Any reproduction – in whole or in parts – is forbidden without ABB's prior written consent.

Copyright© 2004 ABB

All rights reserved.